

# Extrusion Traffic Warning Manual

## INSTALLATION

1. Remove endcap (side without cable) and insert mounting carriage bolts.
2. For Surface Mount, drill 1/4" (6.3mm) holes to the mounting surface.
3. Place Disk Gasket onto each bolt, and insert bolts into mounting holes.
4. Place Lockwasher and Elastic Stop Nut onto each bolt, and tighten firmly.
5. For Bracket Mount (sold separately), refer to mounting bracket manuals.

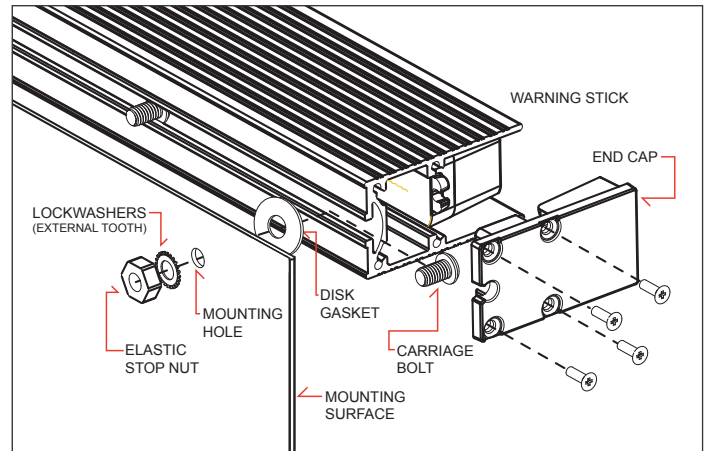

## POWER WIRING

**RED:** to +VDC (with fuse according to the following chart)

Sticks with 3-LED Lightheads		
Heads	Max. Current	Fuse (Amps)
2	0.7	3
4	1.4	3
6	2.1	5
8	2.8	5
10	3.5	5

Sticks with 4-LED Lightheads		
Heads	Max. Current	Fuse (Amps)
2	1.4	3
4	2.8	5
6	4.2	10
8	5.6	10
10	7	10

**BLACK:** to Chassis Ground

## CONTROL WIRING

**WHITE:** for Simultaneous or Alternating Flash

Group1: Sticks with WHITE connected to RED will flash together

Group2: Sticks with WHITE not connected to RED will flash together

\*Group1 will alternate with Group2

**YELLOW:** for Synchronization & Flash Patterns

Connect YELLOW wires of all sticks together for synchronization

\*All sticks must be set at the same pattern

NOTE: Some patterns are not be suitable for synchronization

## FLASH PATTERNS

FP#	FLASH PATTERN	FP#	FLASH PATTERN	FP#	FLASH PATTERN
0	Kit Scan	9	Quint (split)	18	Mega (all)
1	Outside-In Single	10	Mega (split)	19	Ultra (all)
2	Outside-In Ultra	11	Ultra (split)	20	Single-Quad (all)
3	Side-by-Side Single	12	Single-Quad (split)	21	Single H/L (all)
4	Side-by-Side Ultra	13	Single H/L (split)	22	Steady 2 (california)
5	Random	14	Single (all)	23	Steady 4 (all)
6	Single (split)	15	Double (all)	24	Left Chaser
7	Double (split)	16	Quad (all)	25	Right Chaser
8	Quad (split)	17	Quint (all)		

\*(split)=side by side alternating \*(all)=all LEDs on

Momentarily apply +VDC to YELLOW wire:

- Once for next pattern
- Quickly 3 times for reset to FP#0

Note: This unit is not factory set at FP#0

The following FP# are not available in 2 Head Sticks: FP# 0, 1, 2, 3, 4, 24, 25